

TORQUE WRENCH PUMPS

Hydraulic/Electric
Predator Series
10,152 PSI 700 bar

CONSTANT HORSEPOWER PUMP OR HORSEPOWER LIMITING PUMP. QUALITY-ENGINEERED AND PRECISION-MACHINED USING STRONG LIGHTWEIGHT ALLOYS.

PREDATOR SERIES HYDRAULIC ELECTRIC PUMPS

The new Predator Series electric pumps are the first constant horsepower pump or horsepower limiting pump in the portable hydraulic pump market. What can torque wrench users expect? In a word... SPEED.

A few advantages of the Predator Series Pumps:

- Up to twice the tool speed of typical 2-speed pumps
- Continuous Duty Operation
- External Pressure Adjustment
- Four Tool Manifold (Optional)
- Calibratable Gauge
- Roll Bar (Optional)
- Vented Hydraulic Reservoir
- Modular Pumping Cartridges
- 1,500 psi/103 Bar Return Side Relief Protection
- Marathon Lifetime Warranty

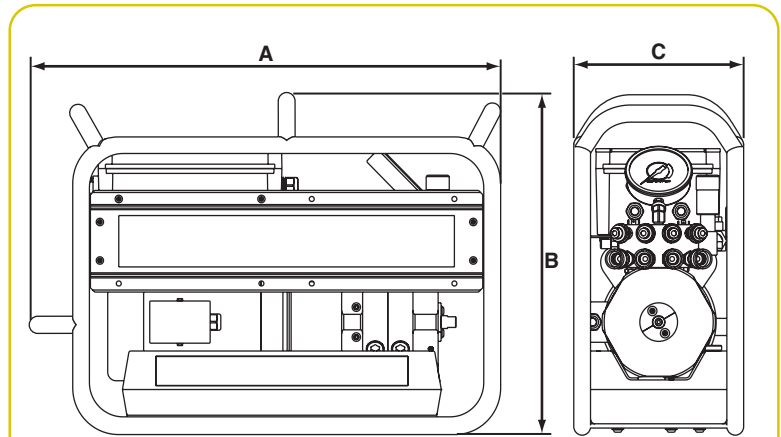

⚠ CAUTION: THIS SYSTEM IS NOT DESIGNED FOR LIFTING. Valving not set up for load-holding.

Patent Pending



Tool Model.	Voltage Freq.	Max. Pressure Output	RPM	dBa at Idle & @10,000 psi & 700 bar	Amp Draw @ @10,000 psi 700 bar	OIL DELIVERY					A	B	C	Product Weight (w/oil)
						@10,000 psi				Reservoir Usable	Height	Width	Length	
						48 bar	172 bar	350 bar	700 bar					
PCHE60A1BA-4	110-120V	10,000psi 700 bar	3,450	75	16	620 in. ³ /min.	237 in. ³ /min.	110 in. ³ /min.	60 in. ³ /min.	231 in. ³	19.88"	10.13"	28.00"	99lbs.
						10.1 L/min.	3.8 L/min.	1.8 L/min.	1 L/min.	3.8L	505mm	257mm	711mm	45kg
PCHE60A1BB-4	110-120V	10,000psi 700 bar	2,850	75	16	620 in. ³ /min.	237 in. ³ /min.	110 in. ³ /min.	60 in. ³ /min.	231 in. ³	19.88"	10.13"	28.00"	99lbs.
						10.1 L/min.	3.8 L/min.	1.8 L/min.	1 L/min.	3.8L	505mm	257mm	711mm	45kg
PCHE60A1BC-4	110-120V	10,000psi 700 bar	3,450	75	8	620 in. ³ /min.	237 in. ³ /min.	110 in. ³ /min.	60 in. ³ /min.	231 in. ³	19.88"	10.13"	28.00"	99lbs.
						10.1 L/min.	3.8 L/min.	1.8 L/min.	1 L/min.	3.8L	505mm	257mm	711mm	45kg
PCHE60A1BD-4	110-120V	10,000psi 700 bar	2,850	75	8	620 in. ³ /min.	237 in. ³ /min.	110 in. ³ /min.	60 in. ³ /min.	231 in. ³	19.88"	10.13"	28.00"	99lbs.
						10.1 L/min.	3.8 L/min.	1.8 L/min.	1 L/min.	3.8L	505mm	257mm	711mm	45kg

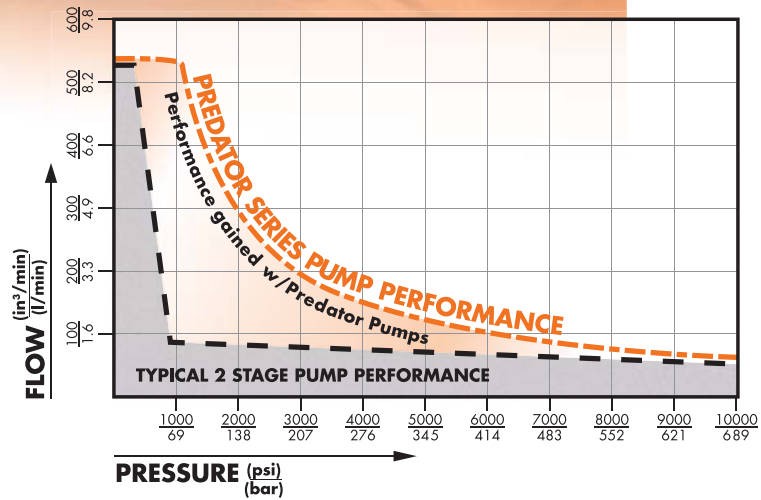

The above chart shows a traditional two stage hydraulic pump flow curve where high flow transitions to low flow at around 700 psi. The chart also shows that the Predator Series pump has much higher flow and flow remains smooth throughout the pressure curve. Flow is continually changing based on pressure, giving the maximum horsepower and flow for that pressure. The

biggest increase in flow is between 1,000 & 5,000 psi.

For tools such as torque wrenches that normally operate between 1,000 & 5,000 psi, the impact is significant – tools operate twice as fast, increasing productivity or getting the job done in much less time.

TORQUE WRENCH PUMPS

Hydraulic/Air Predator Series

**CONSTANT HORSEPOWER
PUMP OR HORSEPOWER
LIMITING PUMP. QUALITY
ENGINEERED AND PRECISION-
MACHINED USING STRONG
LIGHTWEIGHT ALLOYS.**

PREDATOR SERIES HYDRAULIC AIR PUMPS

The new Predator Series air pumps are the first constant horsepower pump or horsepower limiting pump in the portable hydraulic pump market.

What can torque wrench users expect? In a word..... SPEED.

A few advantages of the Predator Series Pumps:

- Up to twice the tool speed of typical 2-speed pumps
- Continuous Duty Operation
- External Pressure Adjustment
- Four Tool Manifold (Optional)
- Calibratable Gauge
- Roll Bar (Optional)
- Sealed Hydraulic Reservoir
- Modular Pumping Cartridges
- 1,500 psi/103 Bar Return Side Relief Protection
- Exhaust air heat exchanger-built in
- FRL included
- Quiet operation



CAUTION: This Pump should not be used for lifting applications

Patent Pending

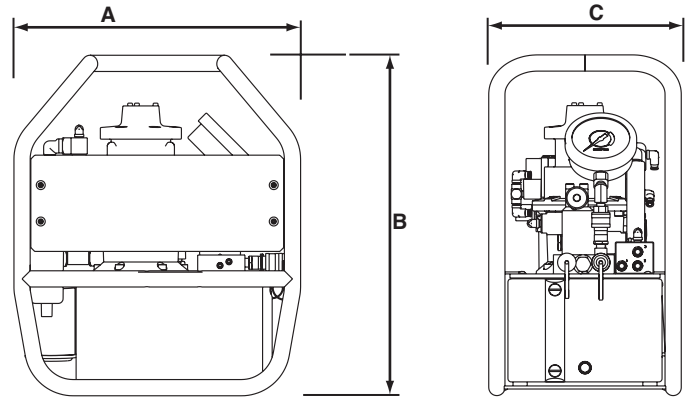

HYDRAULIC TOOLS

Tool Model.	Required Air Pressure	Max. Pressure Output	RPM	dBa at Idle & 700 bar	Reservoir Usable				A Height	B Width	C Length	Product Weight (w/oil)	
					48 bar	172 bar	350 bar	700 bar					
PCHA60T3B0-C	1.4 m ³ /min @ 6 bar	700 bar	3,000	75	19.8 L/min.	7.6 L/min.	3.6 L/min.	2 L/min.	3.8L	505mm	257mm	711mm	36.3kg
	50cfm/ @ 80psi	10,000 psi	3,000	75	1,240 in. ³ /min.	475 in. ³ /min.	220 in. ³ /min.	120 in. ³ /min.		19.88"	10.13"	28.00"	80 lbs

- Continuously variable performance curve offers maximum flow throughout the pressure range for greater productivity
- Designed for heavy-duty, extended cycle operation
- Internal oil path warms exhaust air to avoid freezing while cooling hydraulic oil to achieve optimum oil temperature
- ATEX II, CAT2, GDcT5 Compliant enables application in potentially explosive environments
- FRL Air Preparation Serviceable filter, regulator, lubricator ensures clean, lubricated & consistent air supply

- Easy operator adjustment to achieve corresponding torque values
- 1,500 psi/103 Bar Return Side Relief protection standard protection for return side of tool
- Marathon Lifetime Warranty Offers protection against defects in workmanship & material



CAUTION: This Pump should not be used for lifting applications

Calibratable, vibration damped gauge easy to read 4" diameter, 10,000 psi/700 bar

**Pneumatic remote control
25 ft. cord standard**



**Powerful 4 HP air motor
starts under load & yields up to twice
the flow of other air pumps for greater
application speed & productivity**

**Easily replaceable pump cartridges
minimize downtime & service costs**

**Muffled exhaust protects against elevated
noise to ensure operator comfort**

**Optional roll bar design offers
protection from damage**

**Four-tool manifold option enables application
of up to four torque wrenches for greater
worksite productivity**

HYDRAULIC TOOLS

